

RoHS Compliant Product
A suffix of "-C" specifies halogen & lead-free

FEATURES

- Low $V_{CE(sat)}$
- Excellent DC current gain characteristics
- Complements the 2SD2098

CLASSIFICATION OF h_{FE}

Product-Rank	2SB1386-P	2SB1386-Q	2SB1386-R
Range	82~180	120~270	180~390
Marking	BHP	BHQ	BHR

SOT-89

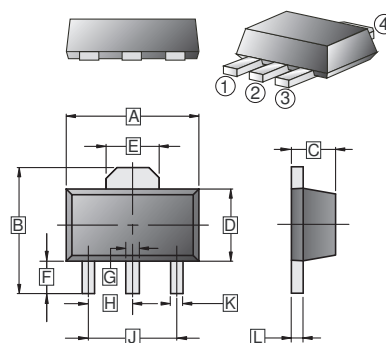

PACKAGE INFORMATION

Package	MPQ	LeaderSize
SOT-89	1K	7' inch

REF.	Millimeter		REF.	Millimeter	
	Min.	Max.		Min.	Max.
A	4.40	4.60	G	0.40	0.58
B	3.94	4.25	H	1.50	TYP
C	1.40	1.60	J	3.00	TYP
D	2.30	2.60	K	0.32	0.52
E	1.50	1.70	L	0.35	0.44
F	0.89	1.2			

ABSOLUTE MAXIMUM RATINGS ($T_A = 25^\circ\text{C}$ unless otherwise specified)

Parameter	Symbol	Ratings	Unit
Collector-Base Voltage	V_{CBO}	-30	V
Collector-Emitter Voltage	V_{CEO}	-20	V
Emitter-Base Voltage	V_{EBO}	-6	V
Collector Current -Continuous	I_C	-5	A(DC)
		-10	A(Pulse) ⁽¹⁾
Collector Power Dissipation	P_D	0.5	W ⁽²⁾
		2	
Junction & Storage Temperature	T_J, T_{STG}	150, -55~150	$^\circ\text{C}$

Note:

- (1) Single pulse, $P_w=10\text{ms}$.
- (2) When mounted on a 40-40-0.7 mm ceramic board.

ELECTRICAL CHARACTERISTICS ($T_A = 25^\circ\text{C}$ unless otherwise specified)

Parameter	Symbol	Min.	Typ.	Max.	Unit	Test Conditions
Collector-base breakdown voltage	$V_{(BR)CBO}$	-30	-	-	V	$I_C=-50\mu\text{A}$
Collector-emitter breakdown voltage	$V_{(BR)CEO}$	-20	-	-	V	$I_C=-1\text{mA}$
Emitter-base breakdown voltage	$V_{(BR)EBO}$	-6	-	-	V	$I_E=-50\mu\text{A}$
Collector cut-off current	I_{CBO}	-	-	-0.5	μA	$V_{CB}=-20\text{V}$
Emitter cut-off current	I_{EBO}	-	-	-0.5	μA	$V_{EB}=-5\text{V}$
Collector-emitter saturation voltage	$V_{CE(sat)}$	-	-	-1.0	V	$I_C/I_B=-4A/-0.1A$
DC current gain *	h_{FE}	82	-	390		$V_{CE}=-2\text{V}, I_C=-0.5\text{A}$
Transition frequency	f_T	-	120	-	MHz	$V_{CE}=-6\text{V}, I_E=-50\text{mA}, f=30\text{MHz}$
Output Capacitance	C_{OB}	-	60	-	pF	$V_{CB}=-20\text{V}, I_E=0, f=1\text{MHz}$

*Measured using pulse current.

CHARACTERISTIC CURVES

● **Electrical characteristic curves**

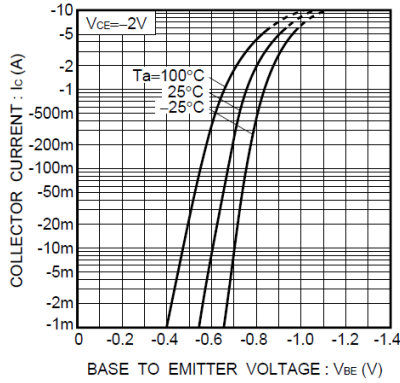

Fig.1 Grounded emitter propagation characteristics

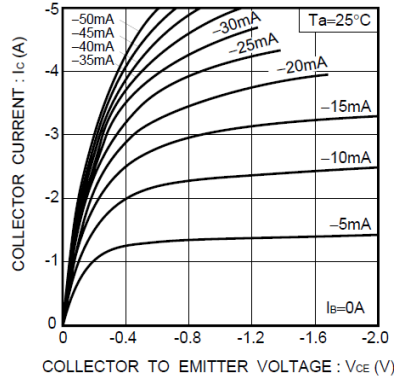

Fig.2 Grounded emitter output characteristics

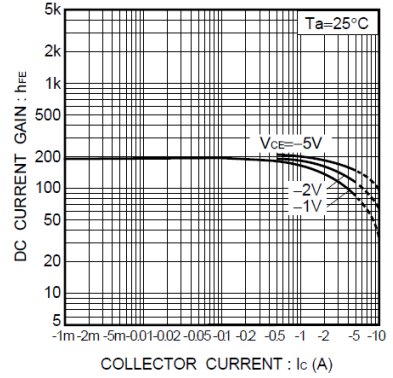

Fig.3 DC current gain vs. collector current (I)

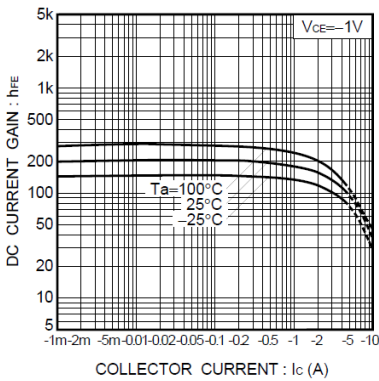

Fig.4 DC current gain vs. collector current (II)

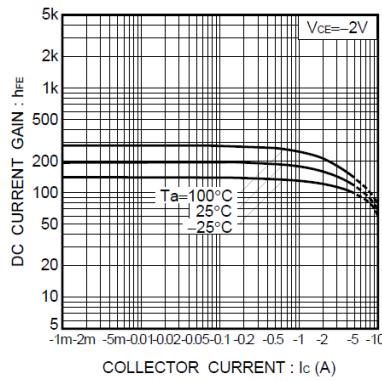

Fig.5 DC current gain vs. collector current (III)

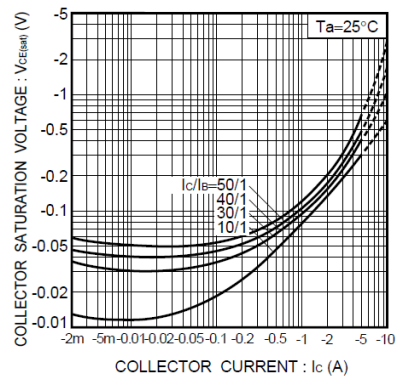

Fig.6 Collector-emitter saturation voltage vs. collector current (I)

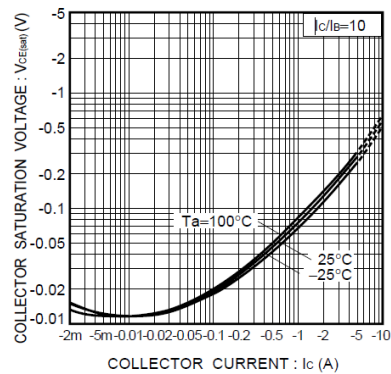

Fig.7 Collector-emitter saturation voltage vs. collector current (II)

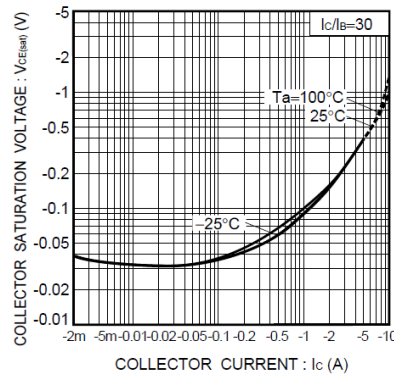

Fig.8 Collector-emitter saturation voltage vs. collector current (III)

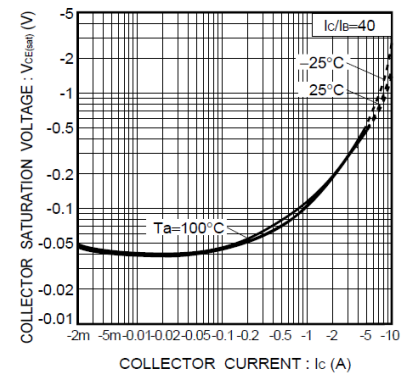

Fig.9 Collector-emitter saturation voltage vs. collector current (IV)

CHARACTERISTIC CURVES

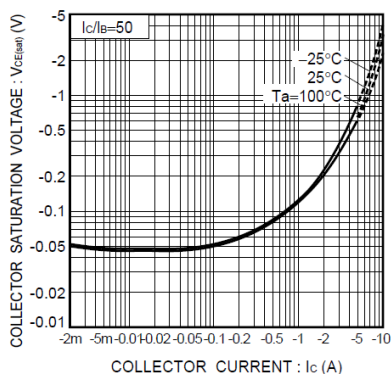

Fig.10 Collector-emitter saturation voltage vs. collector current (V)

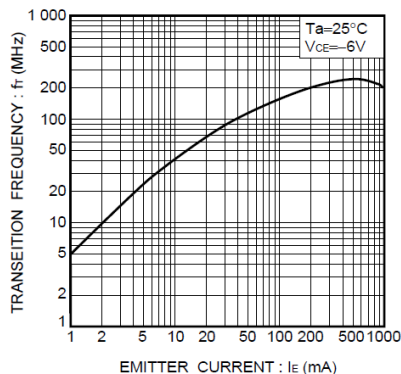

Fig.11 Gain bandwidth product vs. emitter current

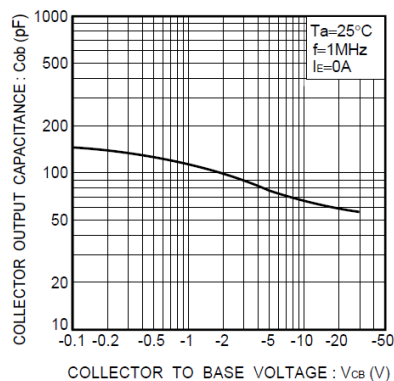

Fig.12 Collector output capacitance vs. collector-base voltage

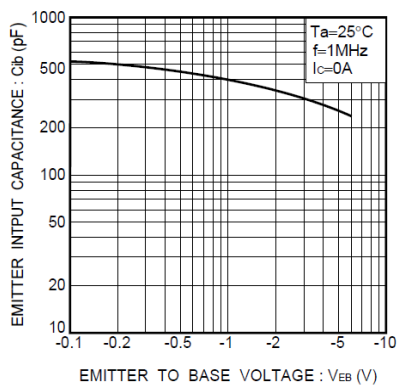

Fig.13 Emitter input capacitance vs. emitter-base voltage